

Furniture – Slatted Litter Bin

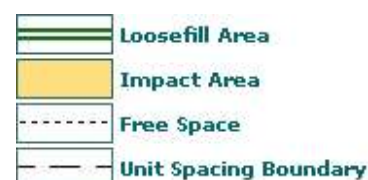
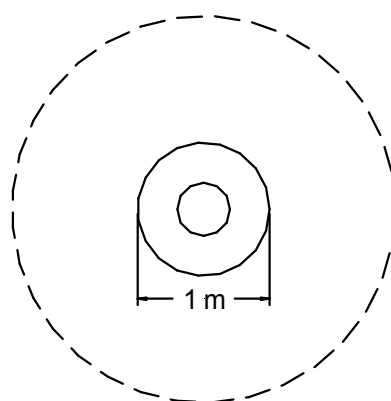
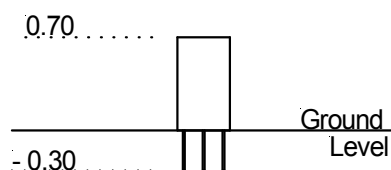

Technical Information

Equipment Dimensions

Length / Width / Height	0.4m x 0.4m x 0.7m
Surfacing And Area Required	
Minimum Space Required L/W/H	1.0m x 1.0m x 2.2m
Max Gradient of Ground	1 in 10
Free Height of Fall	n/a
Impact Area - Wetpour	n/a
Loosefill at 150mm	n/a
Bark / Cushionfall / Sand	n/a
1m x 1m Rubber Tiles	n/a

Installation Information

Overall Weight	15kg
Heaviest Part	10kg
Largest Part	0.4m x 0.4m x 0.7m
Longest Part	n/a
Concrete Required	0.05m³