

Playground Extras – Swing Barriers

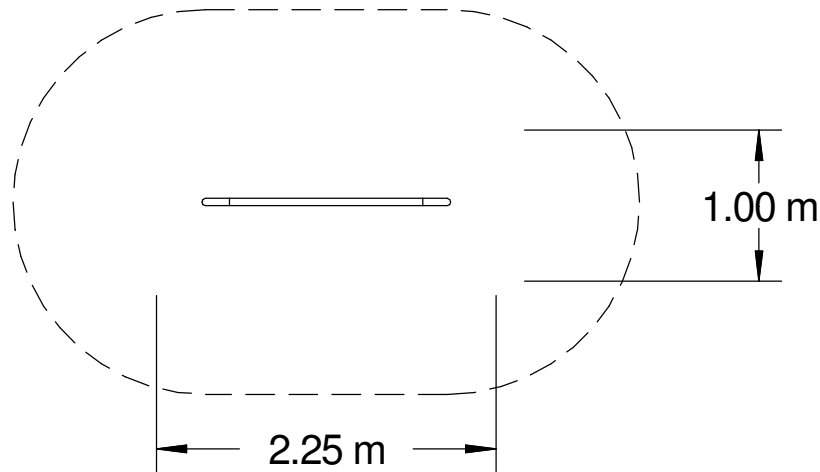
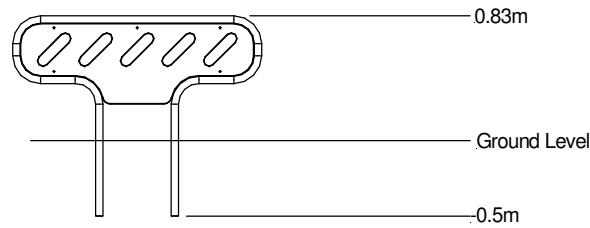

-  Loosefill Area
-  Impact Area
-  Free Space
-  Unit Spacing Boundary

Technical Information		
Equipment Dimensions		
Length / Width / Height	1.65m x 0.05m x 0.83m	
Surfacing and Area Required		
Minimum space required L/W/H	2.25m x 1m x 2.1m	
Max Gradient Of Ground	1 in 20	
Free Height Of Fall	n/a	
Impact Area - Wetpour	n/a	
Loosefill At 150mm	n/a	
Bark / Cushionfall / Sand	n/a	
1m X 1m Rubber Tiles	n/a	
Installation Information		
	Infill	Without Infill
overall weight	26kg	17kg
heaviest part	17kg	17kg
largest part	1.65m x 0.5m x 1.33m	
longest part	n/a	
concrete required	0.09m ³	